

2024 WaveRunner

Yamaha Motor Europe



2024 model & colors



Superjet



Vx Cruiser Ho



Fx Ho Cruiser



Fx Ho



JetBlaster



GP Ho



Fx Svho Cruiser



Fx Svho



VX



GP Svho



Fx Svho Cruiser Ltd

=Speakers

We have four different hulls:

EX: Easy to drive but playful and fun thanks to it's narrow and competitive hull.

VX: True all-round.

Wider and more stable than EX.
New driving position with narrower seat, deeper and wider footwell.

FX: Our biggest hull with extra space and comfort. Better handling and performance in big sea thanks to its length.
Lots of storage and features.

GP: Our most sporty hull with sharp turning characteristics and acceleration.
Many features and improved driving position.

Hull material:

All our hulls are press molded that gives high precision hulls with small tolerances and high finish.

All hulls are made in 4 different composite material.

SMC SMC (Sheet Molded Compound)

NanoXcel Stronger and 25% lighter than SMC

NanoXcel2 Stronger and 37% lighter than SMC
SVHO models, GP & JetBlaster

VaRTM FRP Vacuum Assisted Resin Transfer Molding
Strong and light material used in Superjet

All materials are repairable with glassfiber and epoxy.



ALL NEW 1.9L HIGH OUTPUT

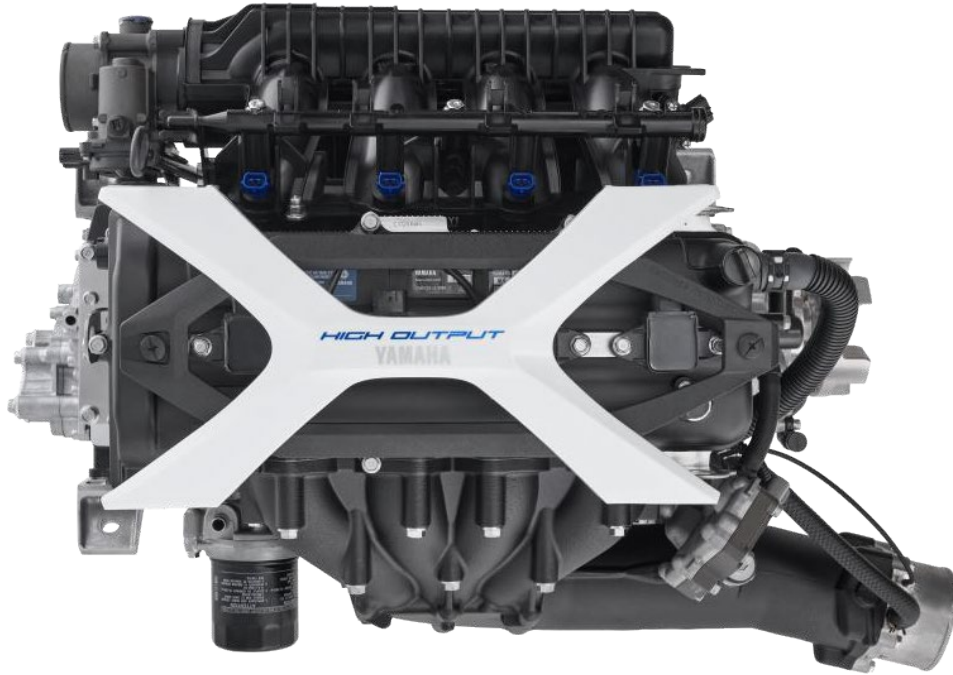

BENEFITS:

- New Style & Appearance
- Larger Displacement
- Higher Power/More Torque
- Quicker & Smoother Acceleration
- Less Noise & Vibration
- Improved Serviceability

ALL NEW 1.9L HIGH OUTPUT



NEW Appearance

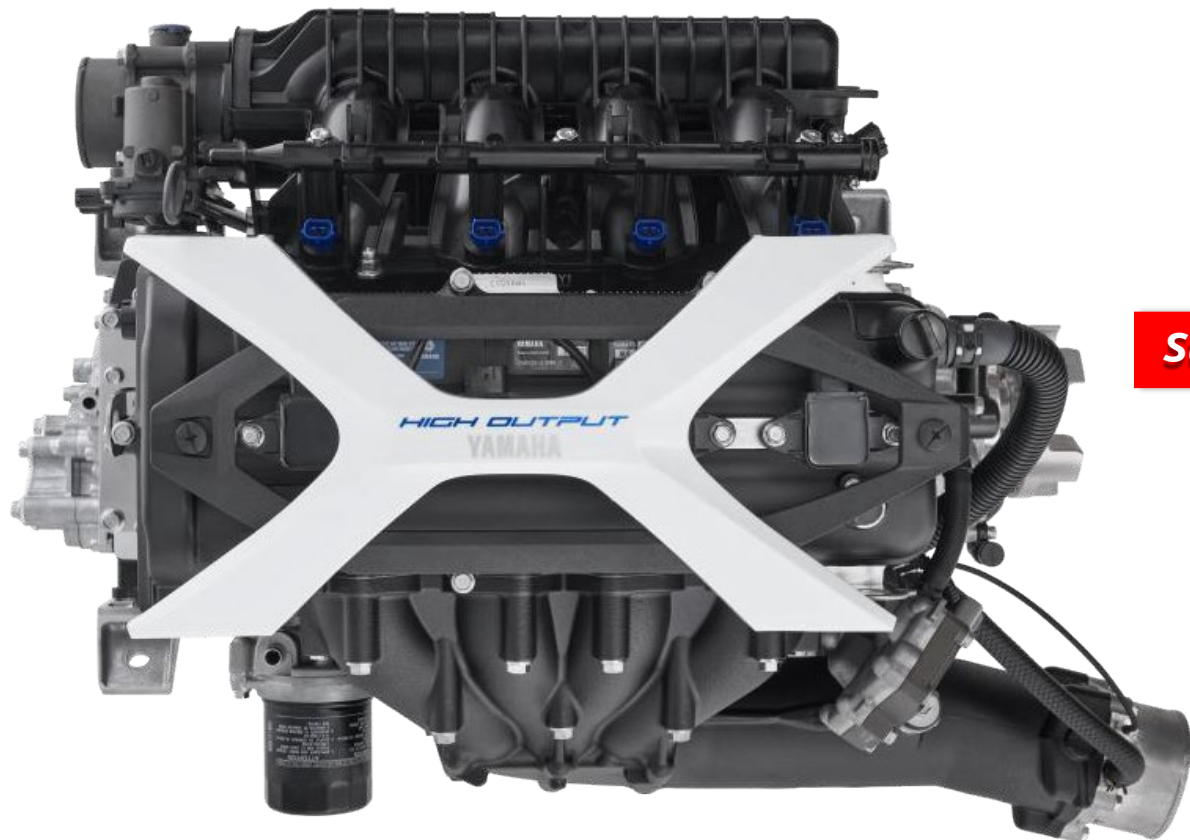

Stylish New Engine Cover

Engine cover is one of the first Yamaha-manufactured parts to include plant-derived cellulose nanofiber (CNF) reinforced resin

- *25% lighter than normal resin materials*
- *Better recyclability*



ALL NEW 1.9L HIGH OUTPUT



NEW Appearance

Matte Black Painted Engine

***Valve Cover, Cylinder Head, Exhaust
Black anodized paint; better look
& more corrosion resistant***

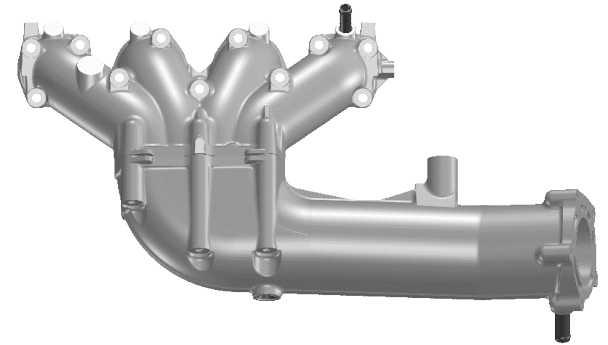
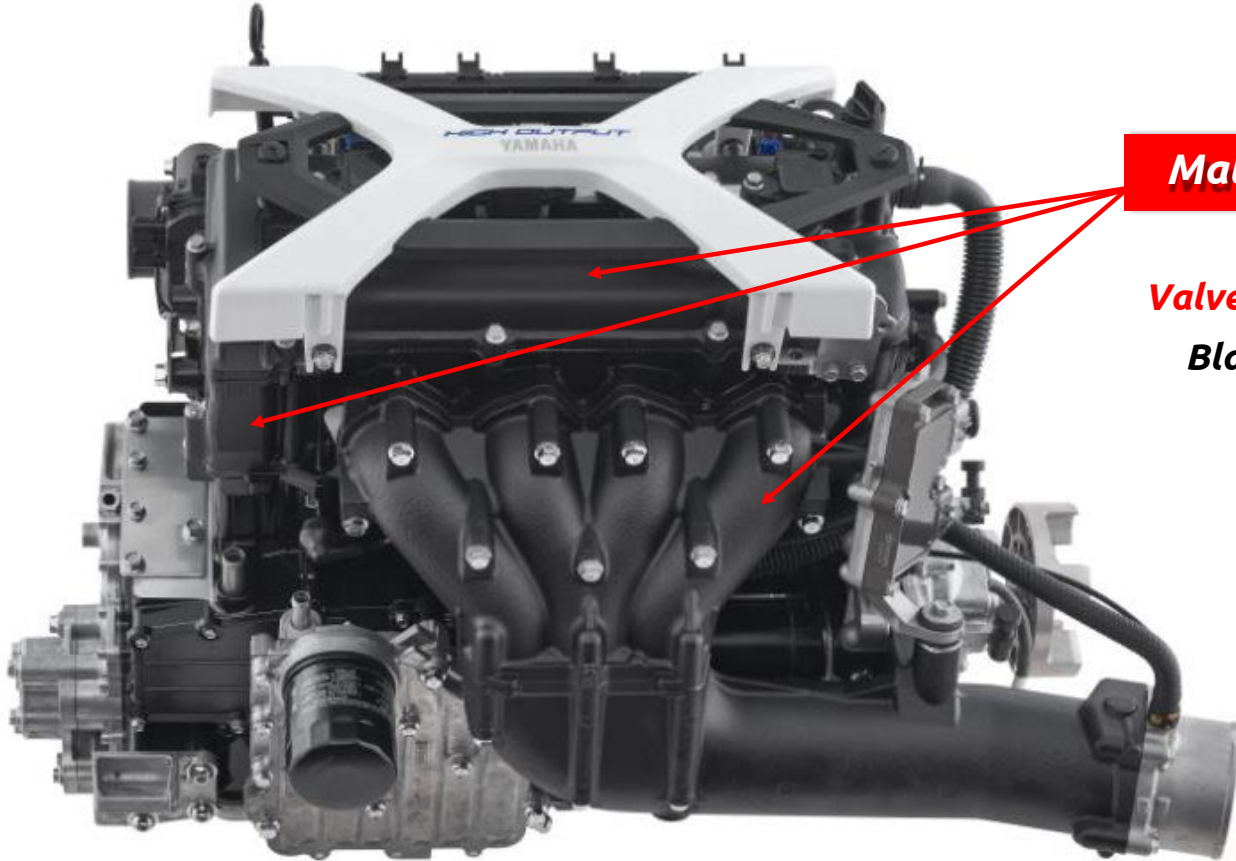

Previous

ALL NEW 1.9L HIGH OUTPUT



Larger Displacement

Maximum Displacement

*Bore up for max displacement
without changing the basic size*

Cylinder Diameter now new 88mm bore

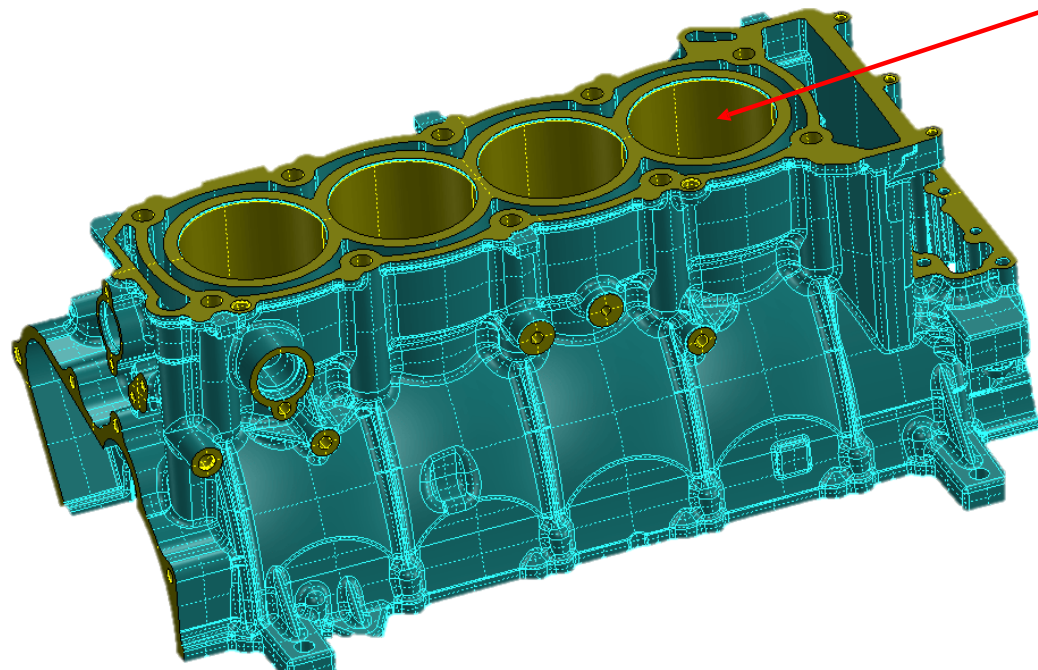

Larger Cylinders

New Pistons

1898cc

87 Octane

All New LARGEST DISPLACEMENT ENGINE in the INDUSTRY

ALL NEW 1.9L HIGH OUTPUT



Redesigned Intake Manifold for Improved Performance

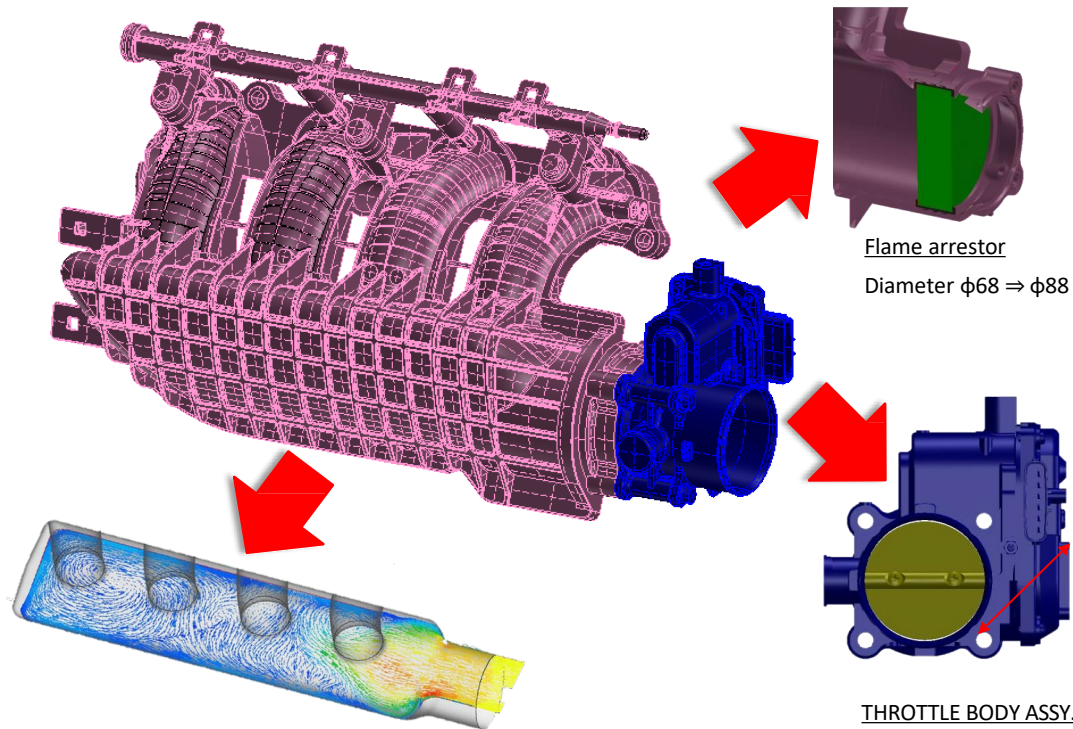

Flame arrestor
Diameter $\phi 68 \Rightarrow \phi 88$

THROTTLE BODY ASSY.
Diameter $\phi 60 \Rightarrow \phi 65$

Pipe length & surge tank optimized for smoother power & performance

1.9L HO Performance

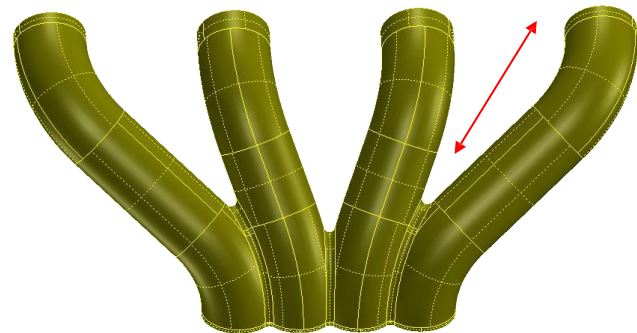

Previous Exhaust Design



Redesigned Manifold =
improved exhaust low

ALL NEW 1.9L HIGH OUTPUT

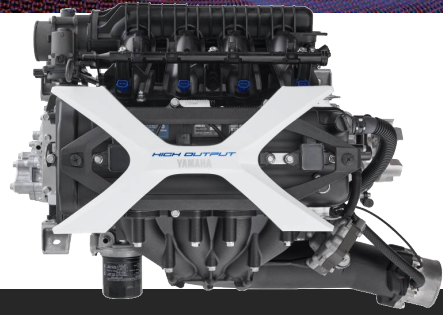

1.9L HO Performance

IMPROVED FX SPEED & FUEL CONSUMPTION!

FX Speed & Acceleration

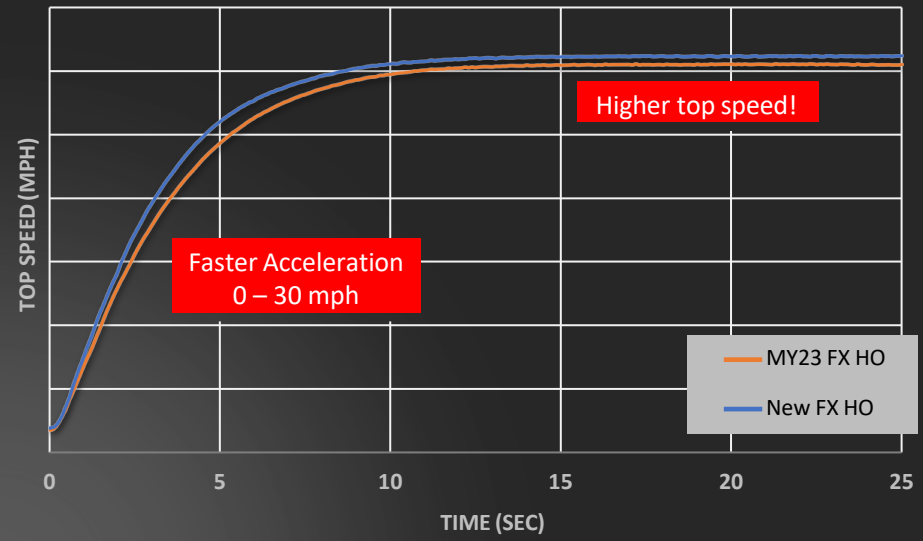

FX Fuel Consumption - Speed vs Fuel

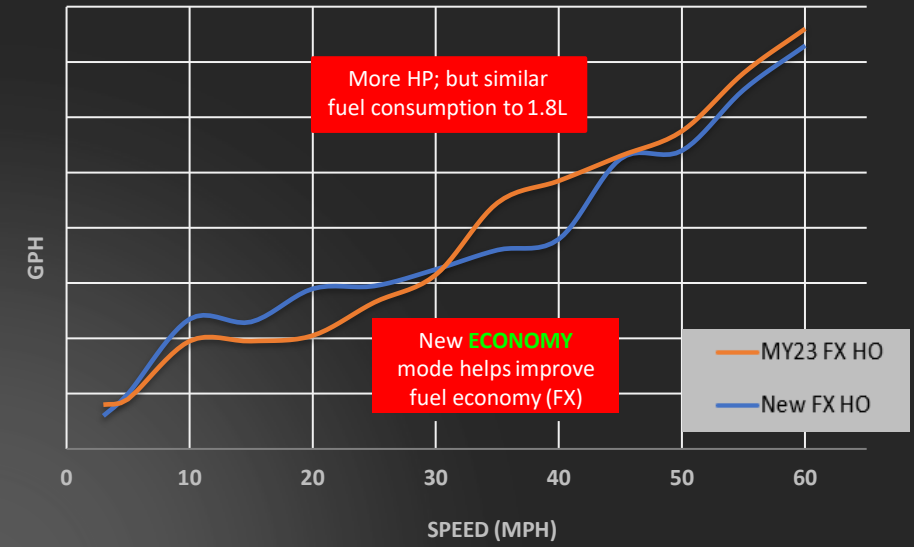

ALL NEW 1.9L HIGH OUTPUT



1.9L HO Performance

New Intake Grates for FX HO & VX HO models

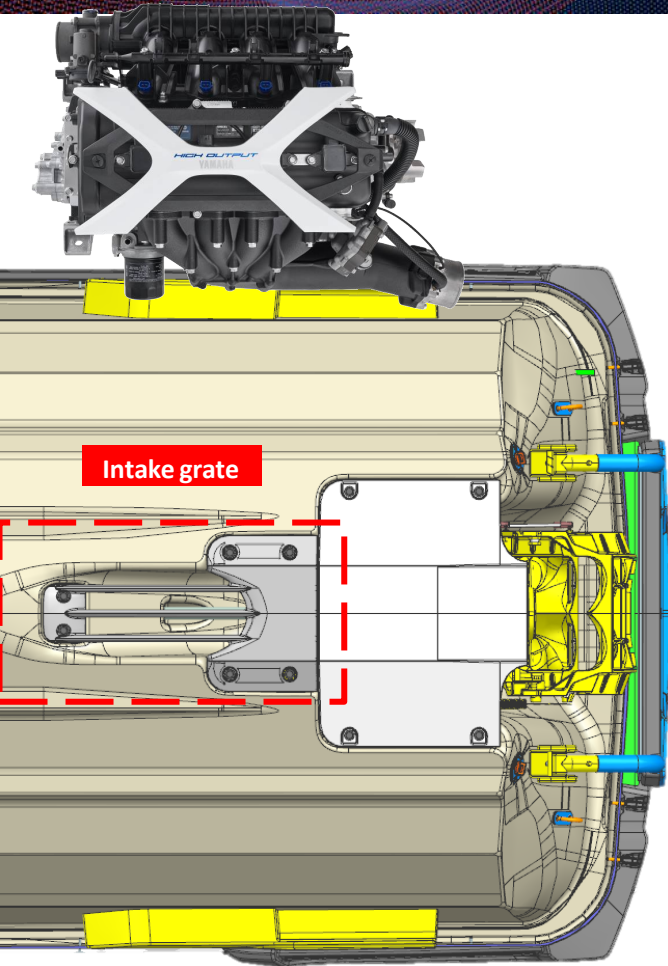

Model	MY23	MY24
FX HO		
VX HO		

Better hookup & stability!

ALL NEW 1.9L HIGH OUTPUT

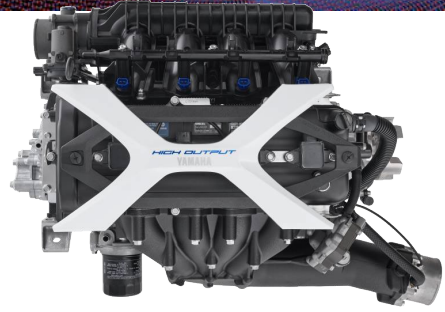

1.9L HO Performance

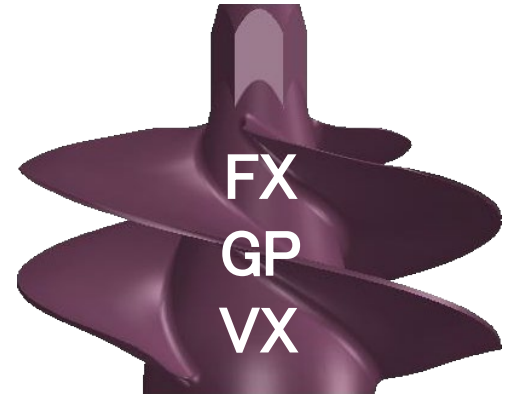
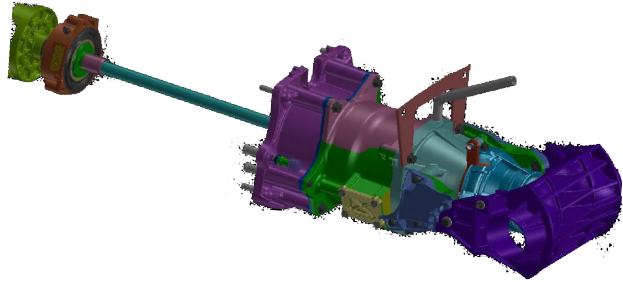

New impeller design – for FX / GP / VX models – with more overlap, to maximize acceleration

ALL NEW 1.9L HIGH OUTPUT

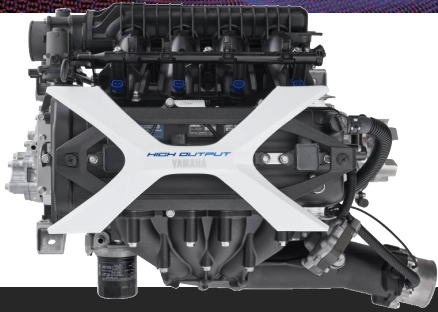

1.9L HO Performance

IMPROVED GP & VX SPEED & ACCELERATION!

GP Speed & Acceleration

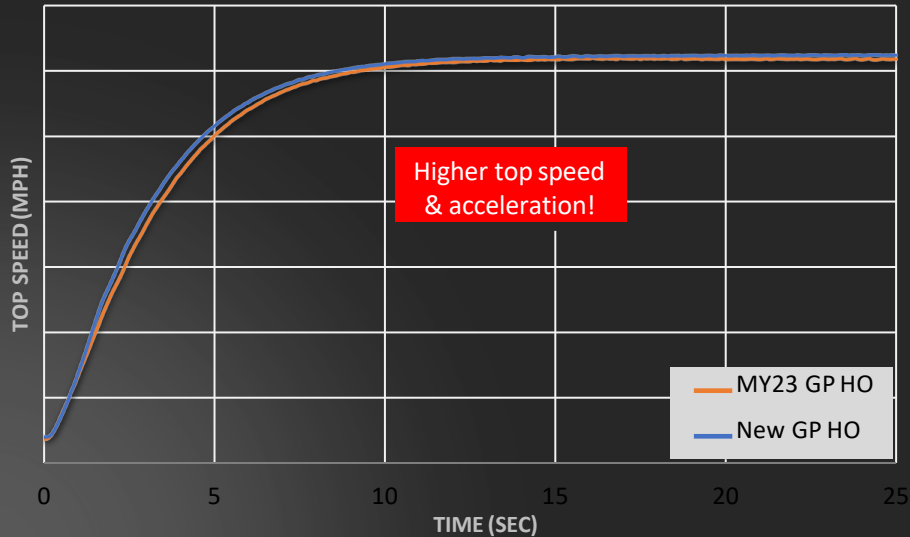

VX Speed & Acceleration

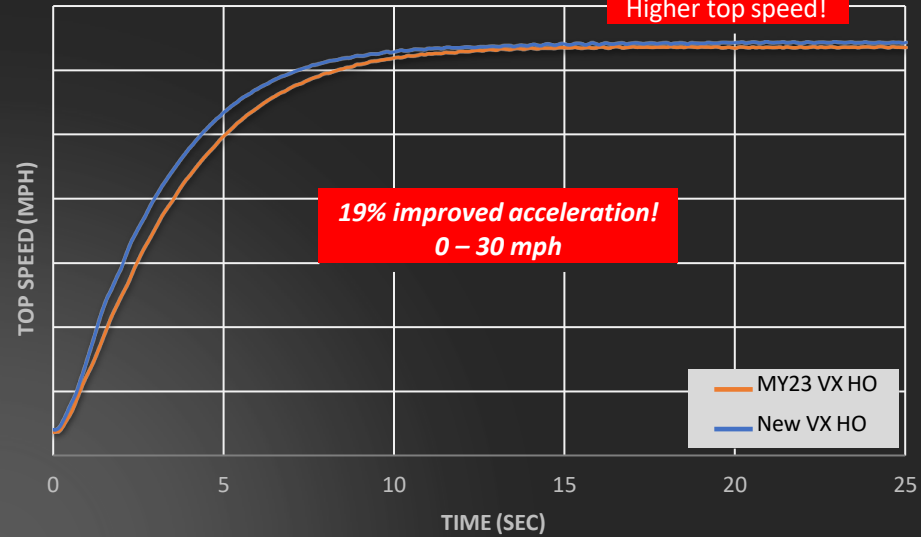

Improved Rotation Fluctuation & Vibration

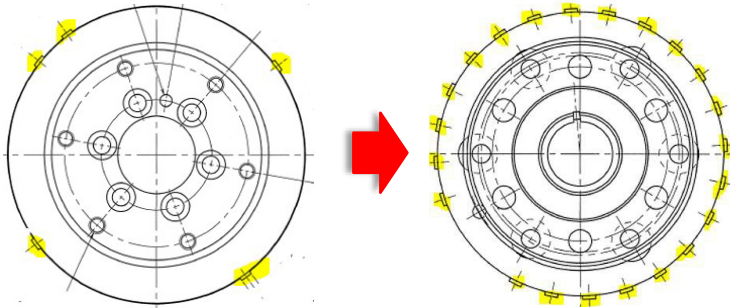

New over-rev limiter control program, helps reduce noise & cavitation

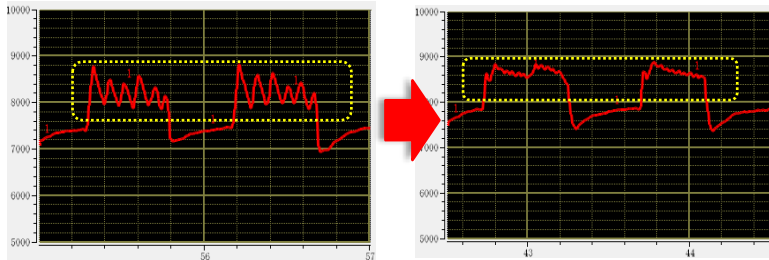

Less Noise & Vibration

MY24 FX Sound Pressure at Driver's Ear

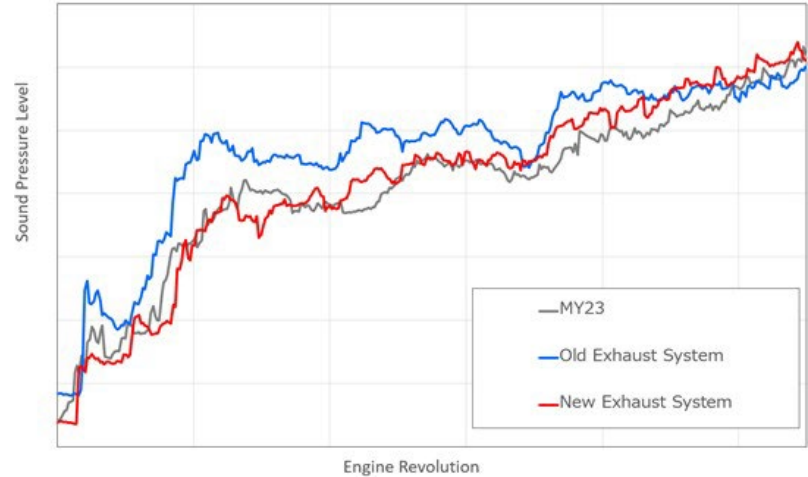

Addition of new resonator helps reduce NVH (3000 – 4000 RPM range)

ALL NEW 1.9L HIGH OUTPUT



Less Noise & Vibration

Larger water tank & resonator to the Exhaust are KEY to lower NVH!

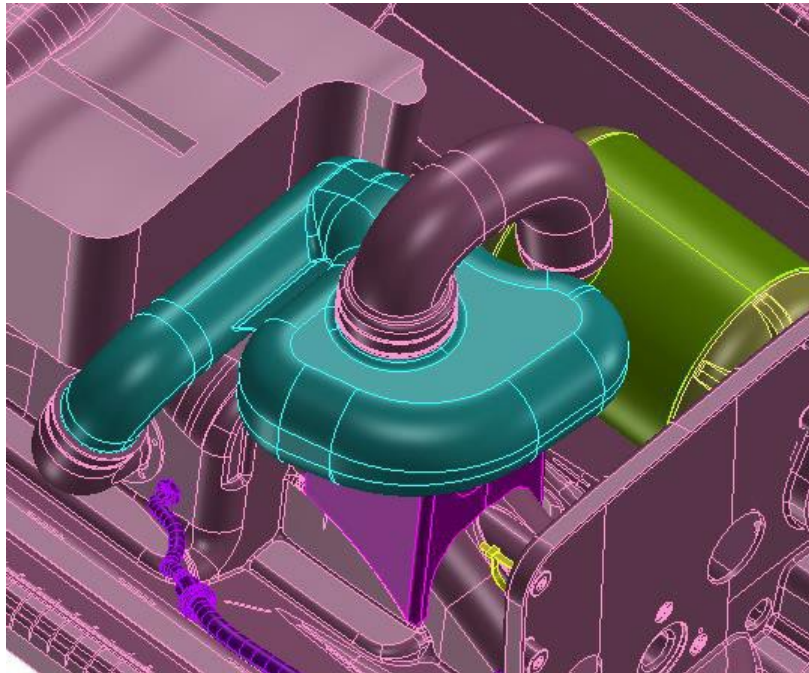

MY23 Exhaust system

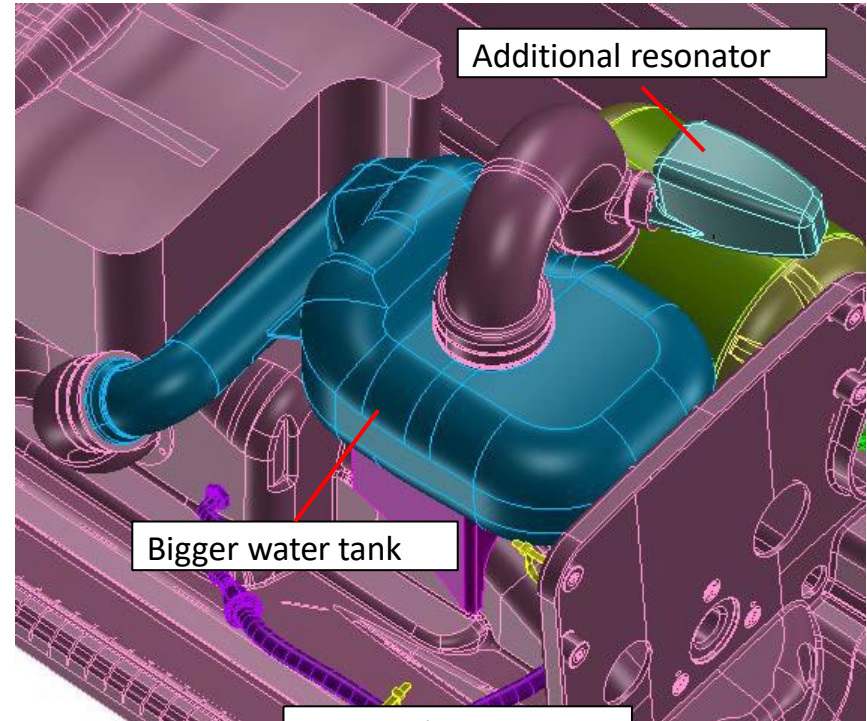

MY24 Exhaust system

ALL NEW 1.9L HIGH OUTPUT



Maintenance & Service

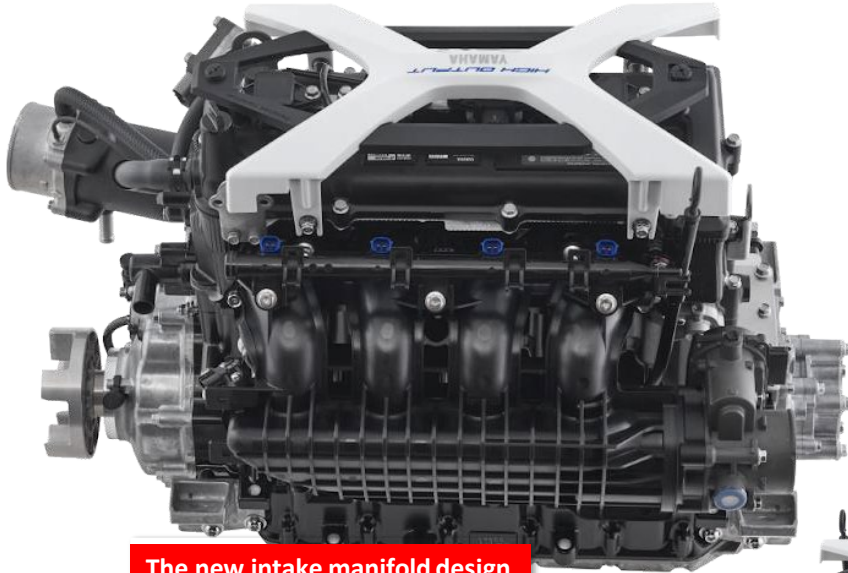

The new intake manifold design shaped for easier removal

Throttle body is a new design with inboard electronics

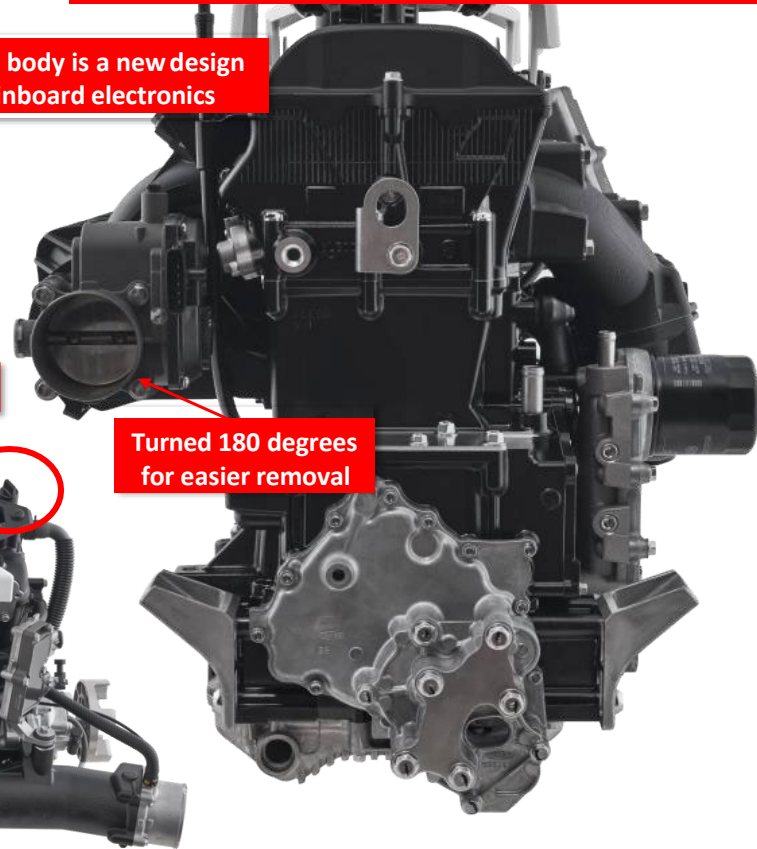

Relocated oil fill

Turned 180 degrees for easier removal

Fewer fastening points for removal

Black anodized exhaust manifold & cover

ALL NEW 1.9L HIGH OUTPUT



WaveRunner Models



VX Cruiser HO



FX HO



GP HO



FX Cruiser HO



Full Size Luxury (FX Series)

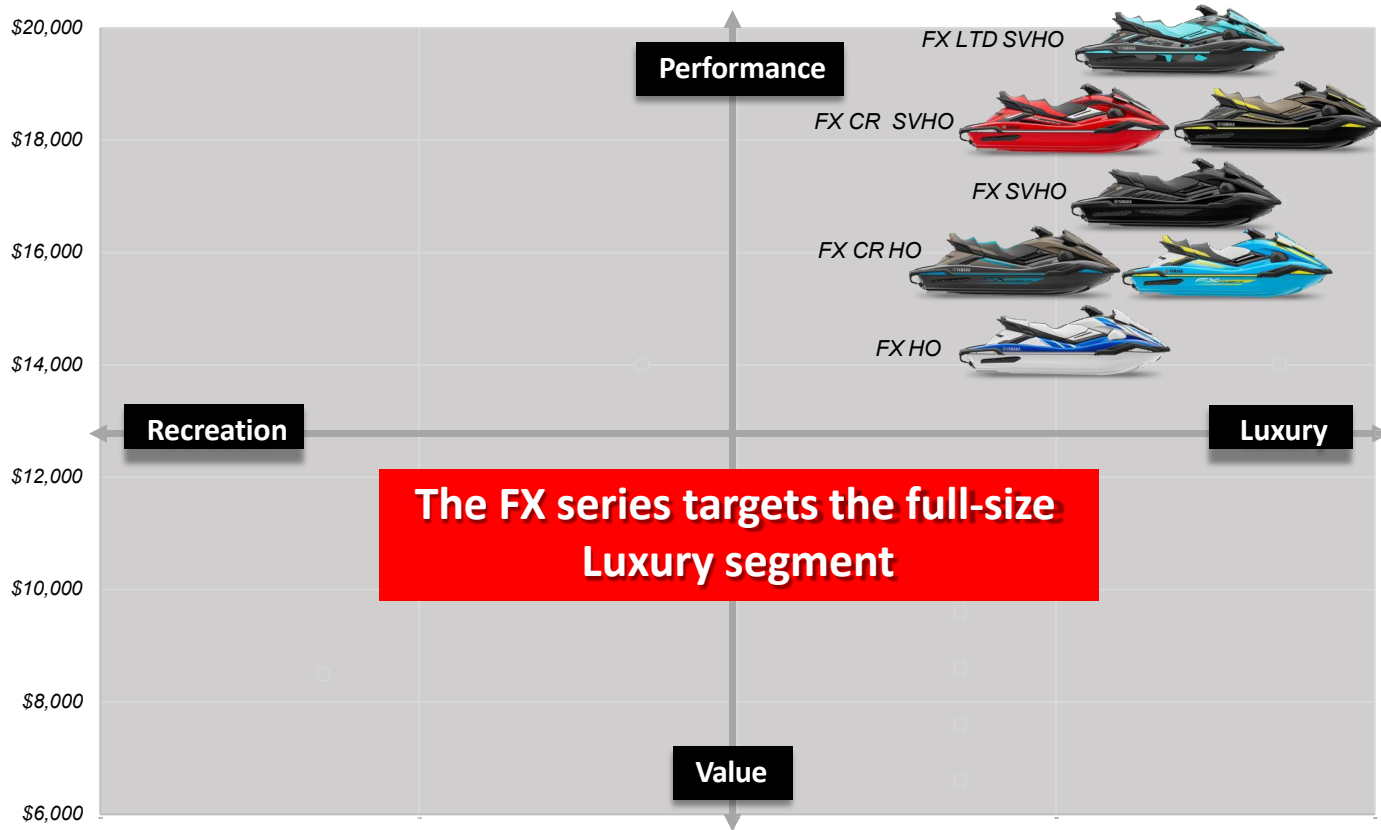

2024 FX Series



New for MY24 Models

7" CONNEXT SCREEN ON ALL FX UNITS



SVHO



HO

New for MY24 Models

Updated Home Screen

Increased visibility for trim and fuel meters

Added Compass

Larger Speedometer and Tachometer

Decreased RPM Arc size

Better visual appearance: gradient throughout display



New for MY24 Models

ALL NEW DRIVE CONTROL MODES



Different color themes based on drive mode



NEW Drive Control Modes

Economy

Made for the most fuel-efficient riding

Trim: **ECO Auto Trim**
Acceleration: **Medium**
Speed: **30mph**

Rider can use Speed Adjust to Increase +10mph (**40mph**)

Economy Icon Displayed

Green "Economy" theme

Optimal RPM rate

Acceleration rate & Speed setting



NEW Drive Control Modes



Light Blue "Comfort" theme

Designed for a smooth and comfortable experience

Trim: **Comfort Auto Trim**
Speed: **No preset**
Acceleration: **No preset**

Comfort Icon
Displayed



NEW Drive Control Modes

⚡ Performance

Designed for aggressive, high-performance riding

Trim: Performance Auto Trim

Speed: No preset

Acceleration: No preset

Red "Performance" theme

Performance Icon Displayed



NEW Drive Control Modes

 **Tow**

The optimal settings for quicker planing and reducing spray while towing

Trim: **Tow Auto Trim**
Acceleration: **Medium**
Speed: **15mph**

Rider can use Speed Adjust to Increase +10mph (**25mph**)

Orange "Tow" theme

Tow Icon Displayed

Acceleration rate and Speed setting



NEW Drive Control Modes

Custom

Ride how you want to. Custom mode lets set your own speed and acceleration as well as select manual or auto trim

Trim: Manual / Performance / Comfort

Speed: 10 ~ 60 mph

Acceleration: Slow, Medium, Fast

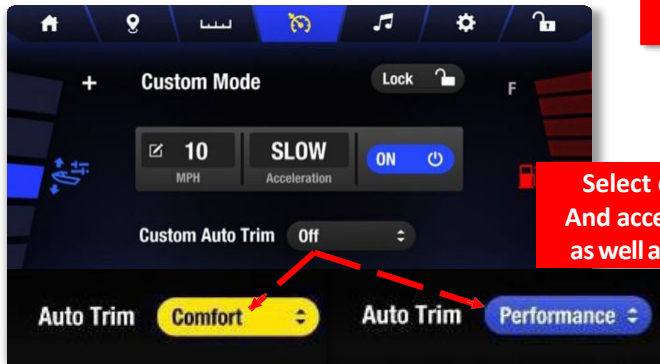

Blue "Custom" theme

Custom Icon Displayed

Select different TRIM And acceleration modes, as well as limit top speed

Acceleration rate and Speed setting



New for MY24 Models



Switch Display screens on Connext screen while riding using the Touch Keypad (under 2500 RPMs)



ON



OFF

Silence Fuel alarm at speed using the Touch Keypad

FX Series Features

Complete Smartphone Connectivity

All FX models receive PHONE CALLS & TEXT Notifications ; GPS Maps Ready

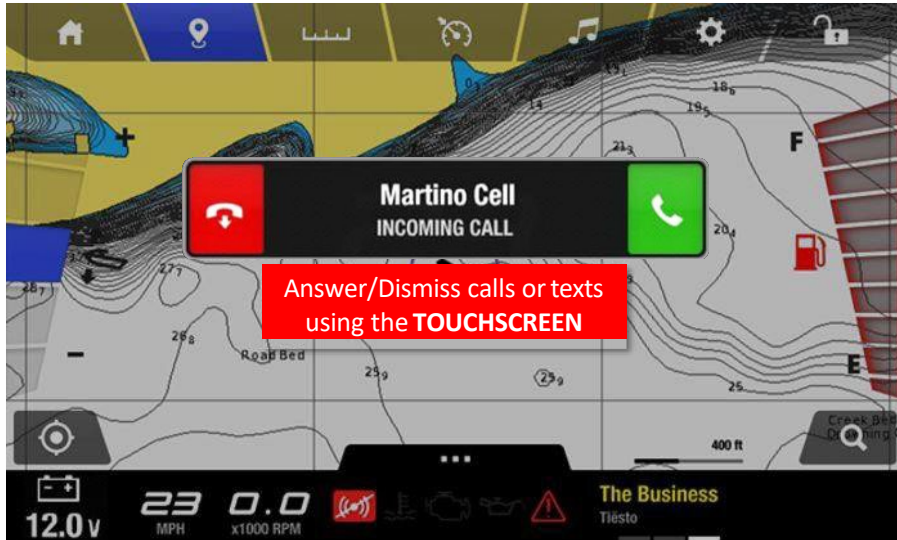

All FX models come standard w/
Integrated Audio Speakers.
(except FX HO)

FX Series – GPS Map

Map ready function : customer need to purchase map data separately



Map data in USB memory
from ENC (vender in US)



Navionics map, available

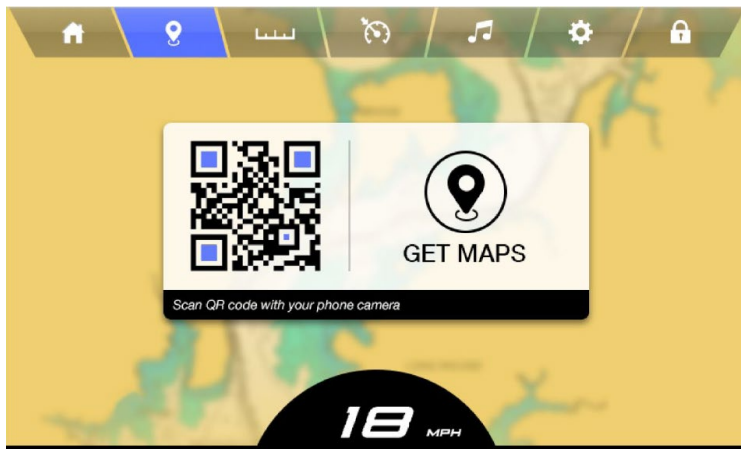
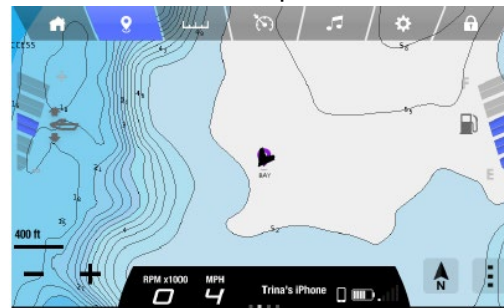

- Customer gets QR code in display at first time use of GPS tab
- Online order through Enovation maps website
- [Installation at Dealer recommended](#)
- www.enovationmaps.com

FX Series Storage

Industry-Leading Storage

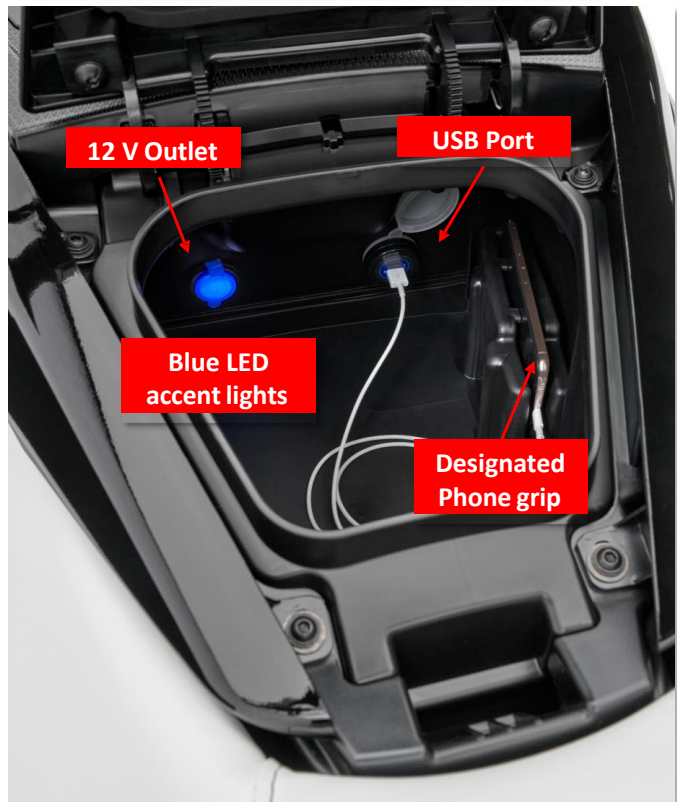

FX Series Features

RiDE: The industry's ONLY dual throttle system

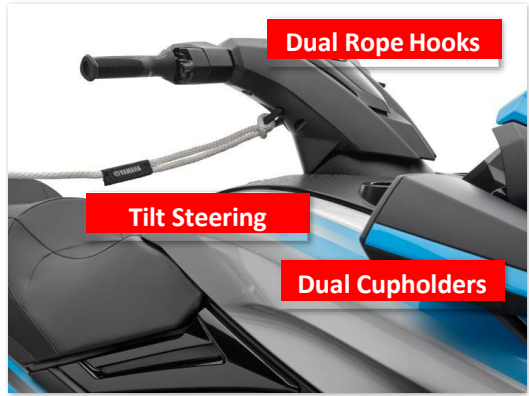

Dual Rope Hooks

Tilt Steering

Dual Cupholders



Cruise Assist
No Wake mode

Adjustable Trim
TDE

FX Series Features



Dual Rope Hooks

Tilt Steering

Dual Cupholders



Three-Tiered Passenger Seating



Multi Mounts



Integrated Audio



Custom Two-Toned Deck Mats



Boarding Step

Choice of Two Engines

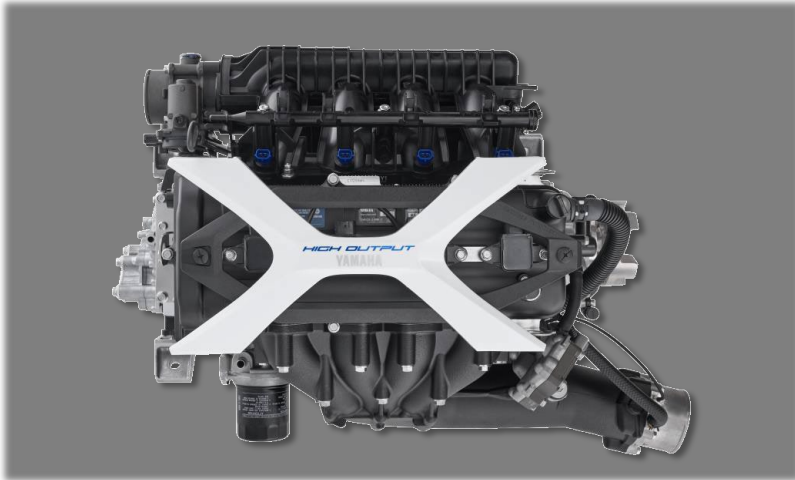

NEW 1.9L High Output

- ALL NEW 1.9L Naturally aspirated
- 1898cc / 195 HP
- Largest displacement in the industry



SVHO

- 1812cc supercharged
- Fastest Acceleration & Top Speed
- High power & torque

2024 FX Series



FX HO



2024 FX Series



FX Cruiser HO



2024 FX Series



FX SVHO



2024 FX Series



FX Cruiser SVHO



2024 FX Series



FX Limited SVHO



Upgraded tow hook



Pull-up Cleats (x2)

ALL NEW PREMIUM COLOR

New color *Copper* with sophisticated graphics.

2024 FX Series



2024 FX Series Lineup





Mid Size Recreation (VX Series)

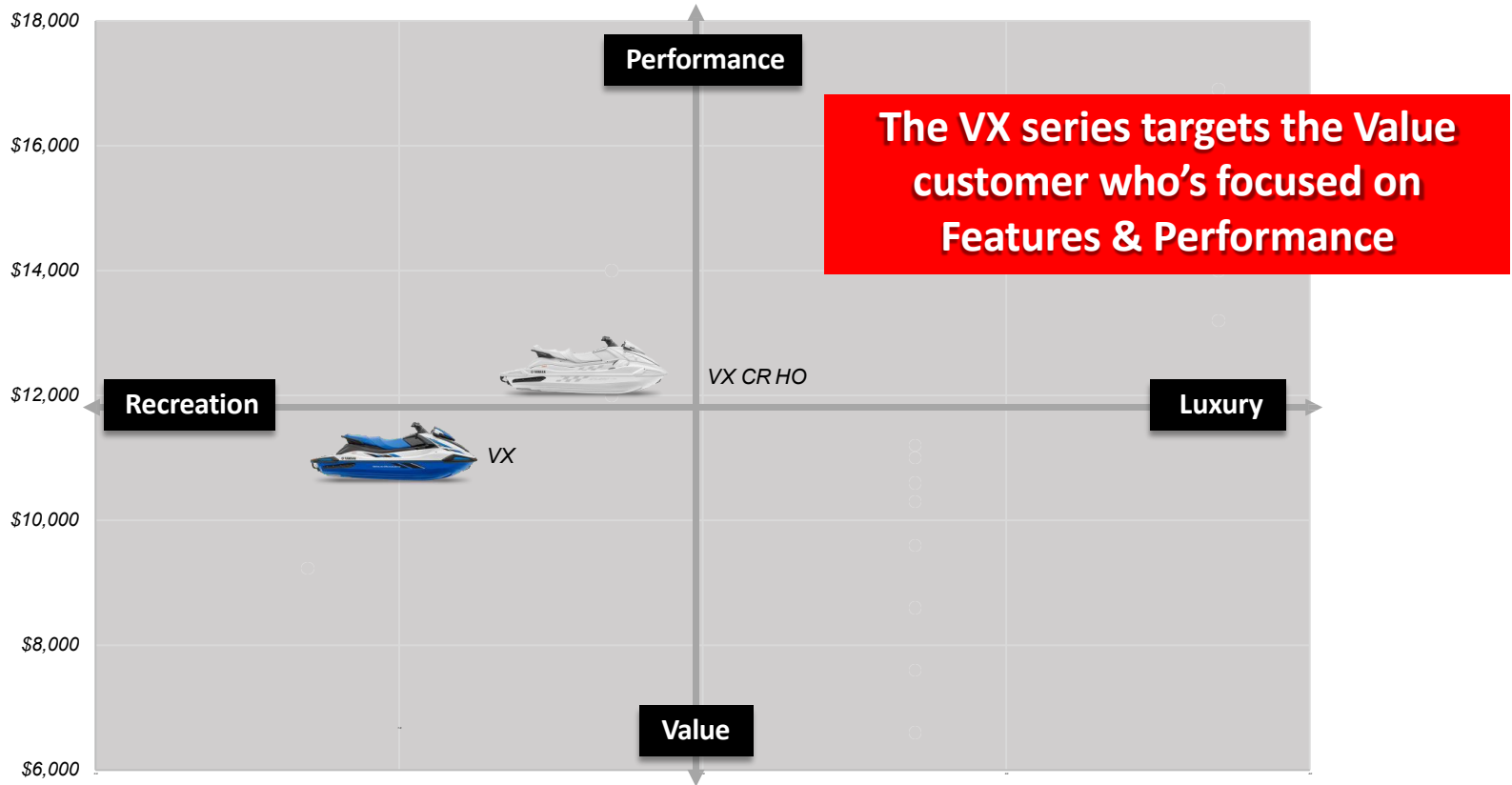

VX Series Features

RiDE: The industry's ONLY dual throttle system

Tow Hook

Reboarding Step
(except VX-C)



Standard on all VX models
(except VX-C)

VX Series Features

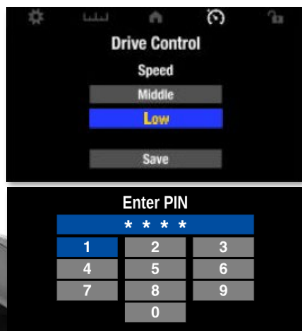

Security Engine Lock
(not on VX or VX-C)

4.3" LCD Connex Screen
(not on VX or VX-C)



VX Series Storage



Front Bow Storage



Watertight Glove Box



Rear Seat Watertight Storage



Choice of Two Engines

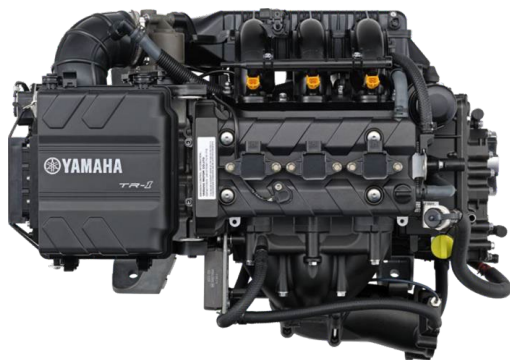

TR-1 HO

- 1049cc, 3-cylinder, naturally aspirated
- Efficient fuel consumption + range
- Lightweight
- Easy maintenance

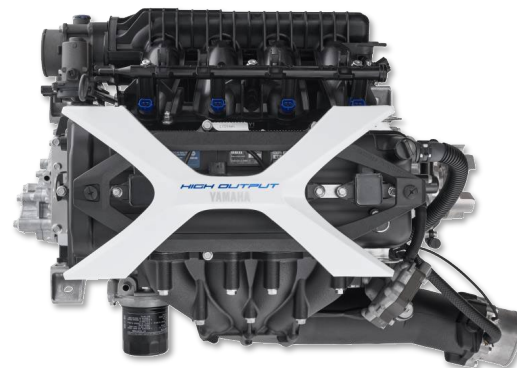

NEW 1.9L HO

- ALL NEW 1.9L Naturally aspirated
- 1898cc / 195 HP
- Largest displacement in the industry

2024 VX Series



VX & VX Cruiser Ho





Performance (GP Series)

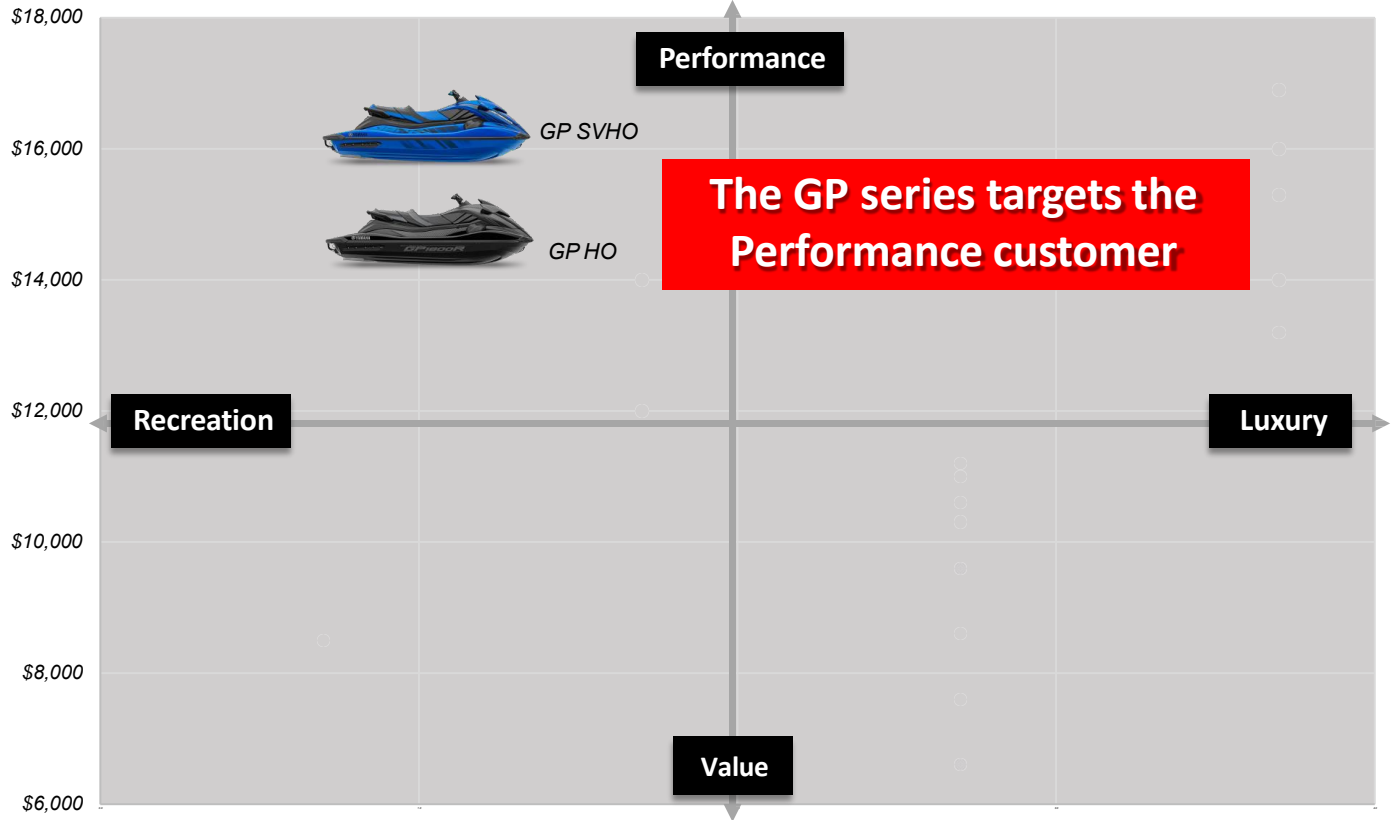

2024 GP Series



GP HO



2024 GP Series



GP SVHO



GP Series Features

Drive Control
Speed/Acceleration
Auto Trim
Lock

RiDE: The industry's ONLY dual throttle system

4.3" Connex Screen



Engine Settings
Trip Details
Drive Control
Engine Lock



Cruise Assist
No Wake Mode
TDE
Electric Trim

GP Series Features



Accessory Multi-Mounts

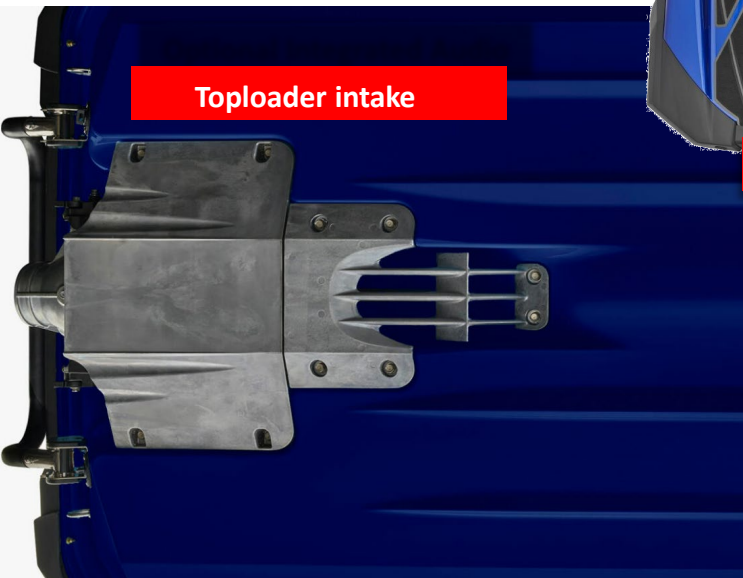

Toploader intake

Custom Two-Tone Mats



Choice of Two Engines

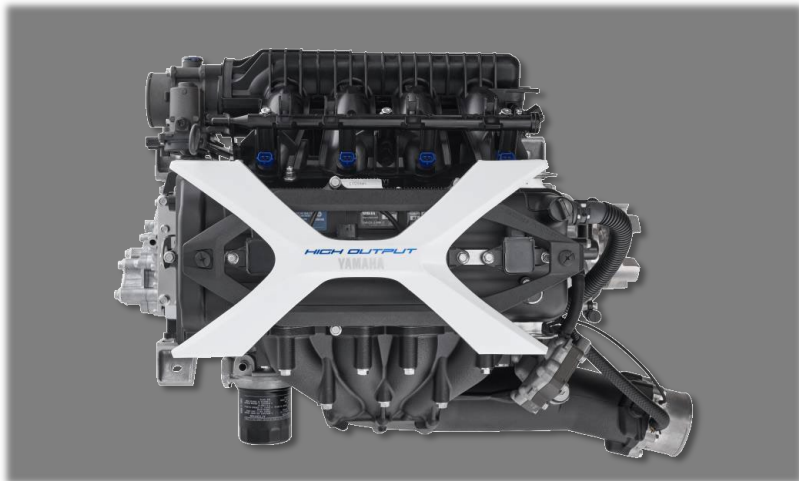

NEW 1.9 High Output

- ALL NEW 1.9L Naturally aspirated
- 1898cc / 195 HP
- Largest displacement in the industry



SVHO

- 1812cc supercharged
- Fastest Acceleration & Top Speed
- High power & torque

2024 GP Series



2024 GP Series Lineup



Freestyle Category





2024 Freestyle Series



JetBlaster



JetBlaster Features



RIDE
Dual Throttle
Control System



Wide, exposed Handlebars



Custom Electronic Trim



Removable Speaker (Accessory)



Custom Foot Chocks



YAMAHA

WAVE-RUNNER
SUPERJET

2024 Freestyle Series



SuperJet



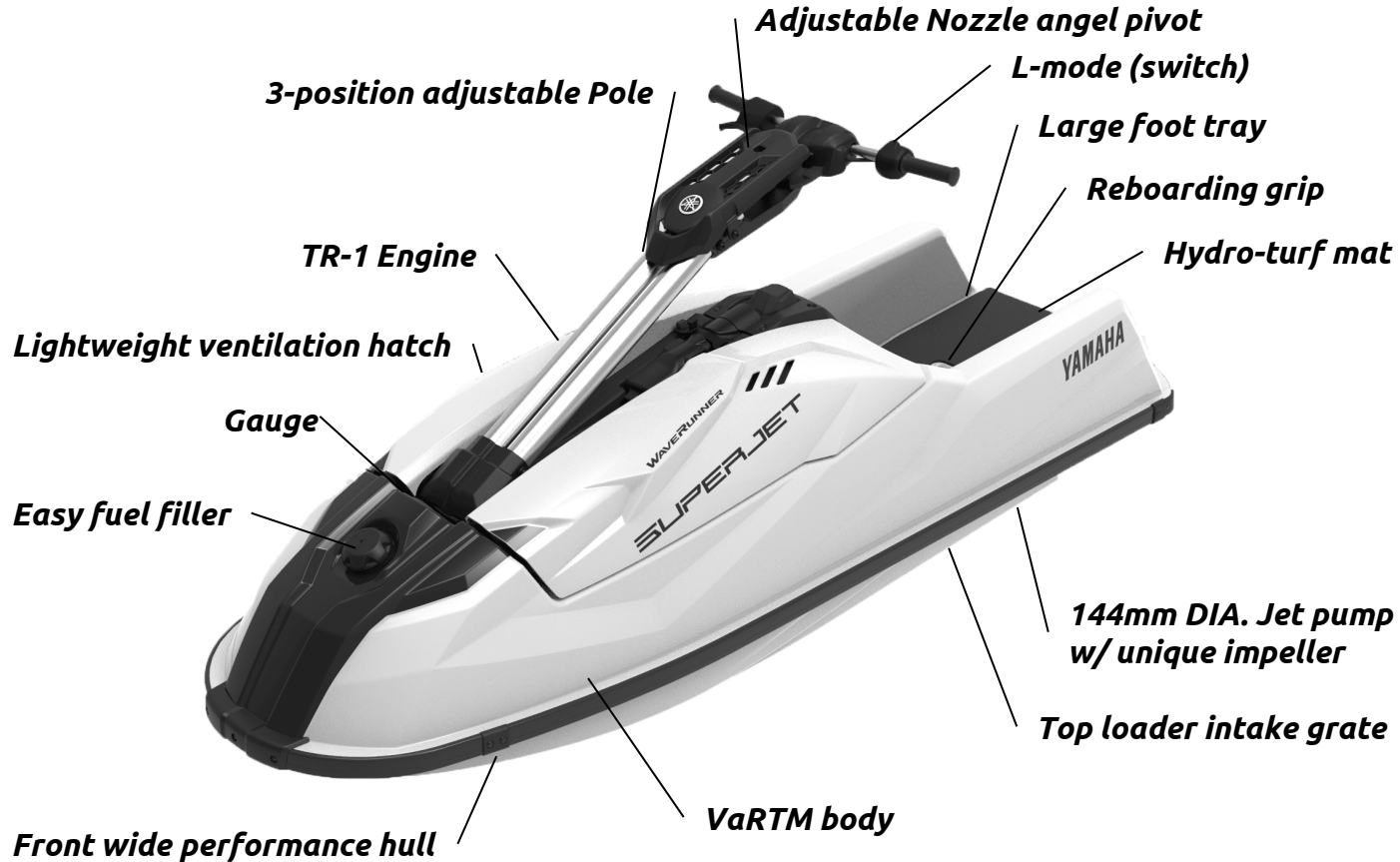

2024 Freestyle Series



2024 Freestyle Series





For full details and specifications



- See WaveRunner Product Information Guide for all details and specifications.
- Available to download on Ympulse under "Yamaha links"

- YML-Yamaha Links
 - Yamaha Training Academy
 - YSR Online
 - SDS website-DK
 - SDS website-NO
 - SDS website-SE
 - Service Portal
 - Visit the Yamaha VI Web Site
 - Visit the Yamaha Web Site
 - Ypec web login DK
 - Ypec web login NO
 - Ypec web login SE
 - Technical Information Web Site
 - Technical Information Website (distributor)
 - Link YMPULSE to a unit parts catalog in YPEC SE
 - Warranty Policy & Operation Manuals
 - Online Rigging Configurator
 - PIG Outboard Motors
 - Yamaha Special Tools 2023
 - 2023 Marine workshop dealer guide
 - 2024 PIG WaveRunner





Thank you

Marine Division